

A 0.015-mm² 60-GHz Reconfigurable Wake-Up Receiver by Reusing Multi-Stage LNAs

Rui Wu, Qinghong Bu, Wei Deng, Kenichi Okada, and Akira Matsuzawa
Department of Physical Electronics, Tokyo Institute of Technology
2-12-1-S3-27, Ookayama, Meguro-ku, Tokyo, 152-8552, Japan
Tel & Fax: +81-3-5734-3764, Email: wu@ssc.pe.titech.ac.jp

Abstract — An area-efficient 60-GHz wake-up receiver (WuRx) using reconfiguration techniques of multi-stage low-noise amplifiers (LNAs) is presented. The gain stages of the 60-GHz LNA are reused as the envelope detectors for the wake-up receiver. Therefore, the bulky components such as extra switches between the wake-up receiver and the LNA, additional antennas, and excess input matching network can be removed in the design of the wake-up receiver. Furthermore, due to the reconfigurability of the LNA, the wake-up receiver can work in sensitivity-boost mode by using several LNA gain stages as a pre-amplifier. The wake-up receiver is fabricated in a 65-nm CMOS process occupying a core area of 0.015 mm² (excluding the LNA). The WuRx achieves the sensitivity of -46 dBm and -60 dBm with a power consumption of $64 \mu\text{W}$ and 12.7 mW , respectively.

Index Terms — CMOS, 60-GHz wake-up receiver, area-efficient, LNA-reused

I. INTRODUCTION

60-GHz transceivers have been demonstrated to be one of the most promising candidates for short-range multi-gigabit-per-second wireless communications [1]. For practical uses of the 60-GHz transceivers, the reduction in power consumption is generally desired, especially for portable devices. It is known that a wake-up receiver (WuRx) is a common solution for reducing the power consumption of the whole system. However, most of the reported WuRxs operate at low frequencies such as 2.4 GHz and 5 GHz [2]–[4]. Extra antennas and matching networks are required for adopting those WuRxs into the 60-GHz transceivers, which causes large area overhead, as shown in Fig. 1(a). In addition, the low frequency bands (e.g. 2.4 GHz and 5 GHz) are becoming crowded as the use of various commercial wireless communication devices increases [3], [5]. It may need more power and area to overcome the interference in those frequency bands. Literature [6] indicates that the WuRx operating in 60-GHz band suffers less from the interference in the networks. Unfortunately, the stand-alone envelop detector requires an extra input matching network if the WuRx is used for the 60-GHz high-speed transceivers. A bulky switch or matching network between the 60-GHz low-noise amplifier (LNA) and the WuRx is also required for

achieving isolation of the two blocks shown in Fig. 1(b).

In this paper, a 60-GHz wake-up receiver with a reconfigurable 60-GHz LNA is presented as depicted in Fig. 1(c). Because the gain stages of the 60-GHz LNA are reused as envelope detectors and pre-amplifiers, the bulky components mentioned above are eliminated in the circuit. Moreover, the sensitivity of the 60-GHz WuRx can be enhanced when several gain stages of the LNA are reconfigured as the pre-amplifier. The proposed WuRx fabricated in a 65-nm CMOS process occupies only 0.015 mm² (excluding the LNA). The WuRx consumes $64 \mu\text{W}$ power from a 1-V supply achieving the sensitivity of -46 dBm. The sensitivity of the WuRx can be improved to -60 dBm with the power consumption of 12.7 mW if several gain stages of the LNA are operated as the pre-amplifier.

II. THE PROPOSED WAKE-UP RECEIVER

The system block diagram of the 60-GHz wake-up receiver with the reconfigurable 4-stage LNA is shown in Fig. 2. The whole system is composed of a 4-stage 60-GHz LNA, a gate bias tuning block, a baseband amplifier, an ID recognition block and a control logic block. The first and fourth stage of the 60-GHz LNA are reused as the envelope detectors for the WuRx. The gate bias tuning block is cooperating with the baseband amplifier to adjust the initial gate biases of the envelope detectors and provide proper gate bias voltages for other gain stages of the LNA. The ID recognition block is utilized to avoid false wake up. The control logic block is designed to switch on/off the circuit components according to the mode selection word.

As mentioned above, the reusing of the LNA gain stages as the envelope detectors can greatly reduce the bulky components when the WuRx is integrated with the 60-GHz transceivers. However, the required circuit topology and bias of the envelope detector are different from those of the 60-GHz LNA. Therefore, some blocks are implemented to reconfigure the 60-GHz LNA. As shown in Fig. 3, a PMOS switch with a shunt resistor is inserted to the supply path of the reused stage of the LNA. When the reused stage is configured as a normal stage of the LNA, the switch is turned on. The switch with the shunt resistor exhibits low

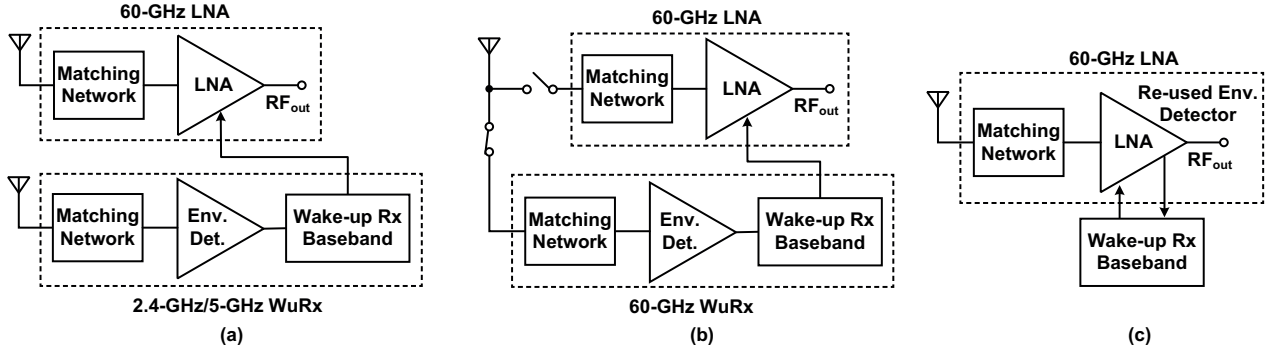

Fig. 1. System block diagram of WuRx for 60-GHz receivers (a) the general 2.4-GHz/5-GHz WuRx; (b) the general 60-GHz WuRx; (c) the proposed WuRx.

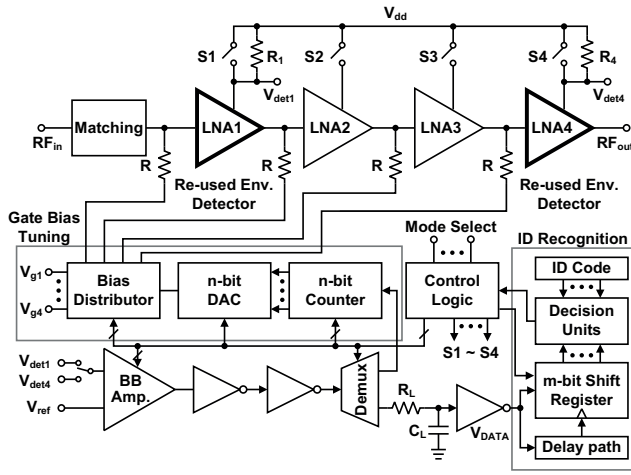

Fig. 2. The detailed system block diagram of the proposed WuRx.

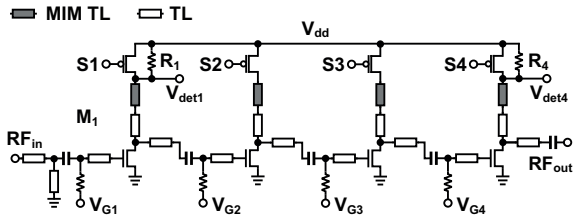

Fig. 3. The detailed schematic of the 4-stage single-ended LNA.

resistance, and will not affect the LNA performance. The equivalent circuit schematic of the 4-stage LNA in normal operation mode is shown in Fig. 4 (a). When the reused stage is reconfigured as the envelope detector, the switch is off showing a required high resistance for the envelope detector as depicted in Fig. 4 (b) and (c). Then the gate bias tuning block cooperating with baseband amplifier is turned on to automatically set the sub-threshold operation point for the envelope detector. Once the sub-threshold bias of the envelope detector is fixed, the baseband amplifier will be disconnected from the gate bias tuning loop by

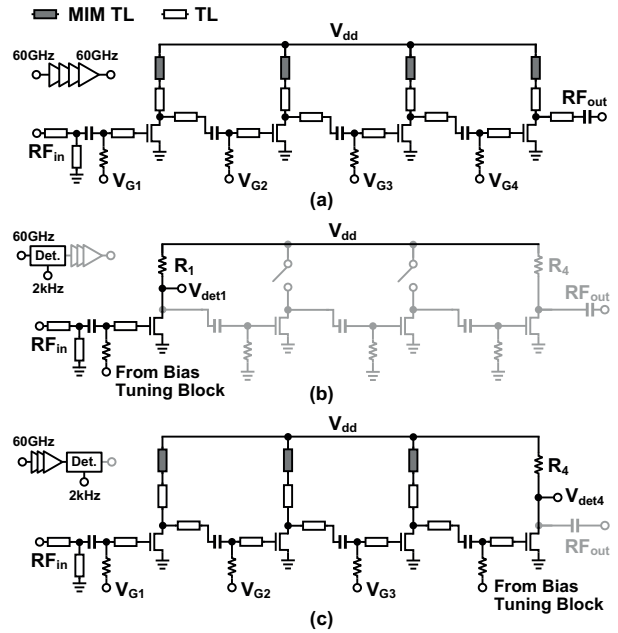

Fig. 4. The equivalent circuit schematic of the 4-stage LNA in (a) normal operation mode; (b) low-power WuRx mode; (c) sensitivity-boosted WuRx mode.

the demux. The WuRx is detecting the wake-up signal afterwards. To avoid false wake up, the ID recognition block is implemented and connected to the output of the baseband amplifier during the detection period. If the received digital sequence is the same as the pre-stored ID code, the decision units will output "1" configuring the LNA back to normal operation mode.

It is worthy of noticing that the WuRx has two operation modes. In the low-power mode, only the first stage of the LNA is reused as the sub-threshold envelop detector, other 3 stages are turned off as illustrated in Fig. 4 (b). In the sensitivity-boosted mode, the first 3 stages of the LNA are used as a pre-amplifier. The fourth stage is the envelope detector shown in Fig. 4 (c). It may be doubted

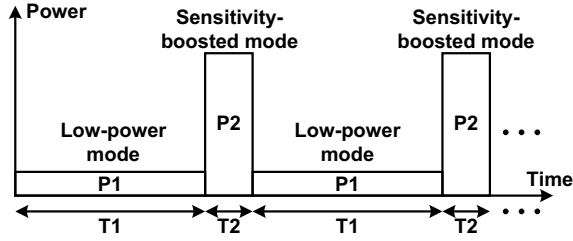

Fig. 5. The simplified duty cycle scheme of the dual-mode WuRx.

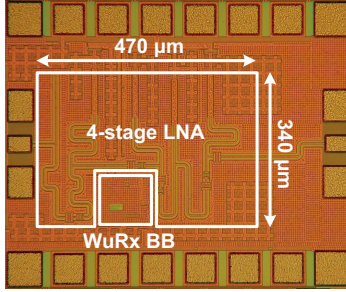

Fig. 6. Die micro-photograph. WuRx: 0.015 mm² (excluding the LNA).

that the improvement of the sensitivity is achieved at the cost of large power consumption. Fortunately, the power consumption of the WuRx can be easily controlled by arranging the duty cycle of the two operation modes. Fig. 5 shows a simplified duty cycle scheme for the dual-mode operation. The average power consumption can be calculated by the following equation.

$$\text{Average Power} = \frac{T1 \times P1 + T2 \times P2}{T1 + T2} \quad (1)$$

For the 60-GHz LNA design, a transmission line (TL) with 1 dB/mm loss around 60 GHz is used for matching networks. An MIM transmission line (MIM TL) is employed for the de-coupling of the power supplies [7]. The schematic of the 4-stage single-ended LNA is shown in Fig. 4 (a). The channel widths of the transistors from input to output terminal are 1.5×24 μm, 1.5×24 μm, 2×20 μm, and 2×20 μm, respectively. The multi-stage gain peaking technique [7] is adopted for realizing wide and flat gain characteristics which is desired for 60-GHz high-speed wireless communications. The input and inter-stage matching networks are carefully designed for achieving reasonable reflection at the RF_{in} terminal for both LNA and WuRx operation modes.

III. MEASUREMENT RESULTS

To verify our design, the proposed WuRx with the reconfigurable 4-stage LNA is fabricated in a 65 nm CMOS technology. Fig. 6 shows the die micro-photograph of the

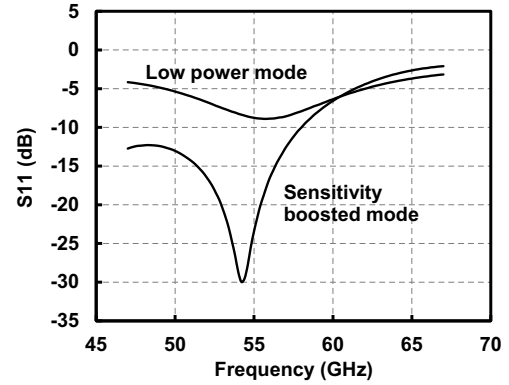

Fig. 7. The measured input reflection coefficient of the WuRx at two different operation modes.

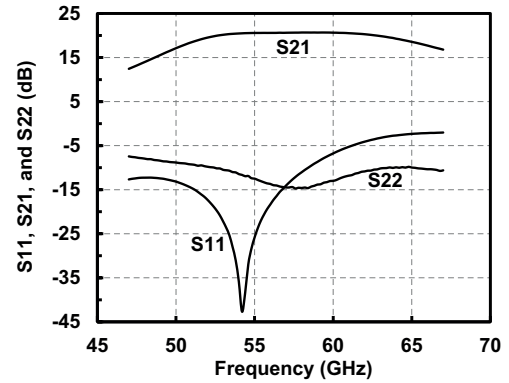

Fig. 8. The measured S parameters of the 4-stage LNA.

whole system. The area overhead of the proposed WuRx is only 0.015 mm² thanks to the reconfigurability of the LNA. The chip is measured on wafer using probe station. The measured input reflection coefficient (S11) of the WuRx at the terminal RF_{in} is depicted in Fig. 7. The S11 is around -10 dB at the frequency band of interest for both low-power mode and sensitivity-boosted mode.

Fig. 8 shows the measurement results of the S parameters when the system is operated as a 4-stage 60-GHz LNA. The peak gain is 20.7 dB at 59 GHz with a power consumption of 17.5 mW from 1-V supply. The -3 dB-bandwidth is from 50.5 GHz to 66 GHz.

The sensitivity of the WuRx is characterized using a signal generator and an oscilloscope. The amplitude modulated 57-GHz signal is produced by the signal generator, which is fed to the input terminal of the WuRx (RF_{in}). A 2-kHz envelope signal is used in the measurement. The output terminal of the WuRx (V_{DATA}) is connected to the oscilloscope through an external first-order band-pass filter (1 kHz-10 kHz). The received signal-to-noise ratio (SNR) is obtained from the data stored in the oscilloscope after Fast-Fourier Transform. The sensitivity

TABLE I
PERFORMANCE COMPARISON OF THE STATE-OF-THE-ART WURXS IN CMOS PROCESSES.

Ref.	Frequency	Area Overhead	Extra Antenna/ Switch Required	False Detection	Sensitivity	Power
[2]	0.9 GHz	2.886 mm ²	Yes	Yes	-73 dBm	9 μ W
[3]	5.8 GHz	0.114 mm ² *	Yes	Yes	-45 dBm	54 μ W
[4]	0.915 GHz	0.36 mm ²	Yes	No	-80 dBm	51 μ W
	2.4 GHz				-69 dBm	
[6]	60 GHz	1.09 mm ²	Yes	No	—	9 μ W
This work	60 GHz	0.015 mm²	No	Yes	-46 dBm	64 μ W
					-60 dBm	12.7 mW

* Estimated from literature

of the WuRx is defined as the input power resulting a received SNR of 12 dB, which corresponds to the bit-error rate (BER) of 10^{-3} for amplitude-shift keying (ASK). The measured sensitivity of the WuRx is -46 dBm and -60 dBm with a power consumption of 64 μ W and 12.7 mW, respectively. Fig. 9 demonstrates the measured spectrum of the received signal when the input power of the WuRx (P_{in}) is equal to -60 dBm. The WuRx is operated in sensitivity-boosted mode, and the measured SNR is 12.1 dB. As described in Section II-A, the average power consumption of the WuRx can be reduced to 77 μ W if the sensitivity-boosted mode is activated for 0.1% duty cycle.

Table I summarizes and compares the performance of the proposed WuRx with that of the state-of-the-art WuRxs in CMOS processes. The proposed WuRx shows the smallest area overhead and least requirement of extra bulky components with reasonable sensitivity and power consumption.

IV. CONCLUSION

This paper presents an area-efficient WuRx for 60-GHz high-speed wireless communication systems by reconfiguring the multi-stage LNA as envelope detectors. Due to the proposed reconfiguration technique, the WuRx requires an area overhead of only 0.015 mm² and does not need extra bulky components to be integrated with the 60-GHz transceivers. The WuRx also achieves the sensitivity of -46 dBm and -60 dBm with a power consumption of 64 μ W and 12.7 mW, respectively. The average power consumption of the WuRx can be easily regulated by the duty cycle control technique.

ACKNOWLEDGMENT

This work was partially supported by MIC, SCOPE, STARC, and VDEC in collaboration with Cadence Design Systems, Inc., and Agilent Technologies Japan, Ltd.

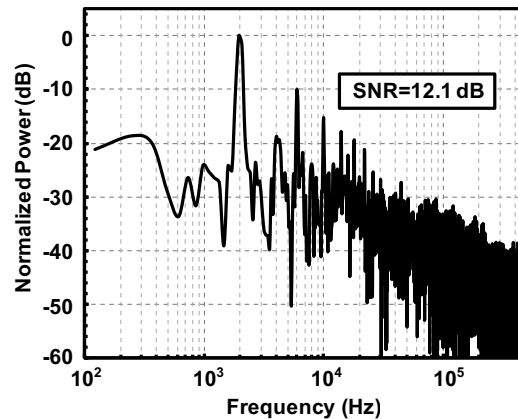

Fig. 9. The measured spectrum of the received signal for $P_{in} = -60$ dBm (WuRx: sensitivity-boosted mode).

REFERENCES

- [1] K. Okada, *et al.*, "A 64-QAM 60 GHz CMOS transceiver with 4-channel bonding," in *IEEE ISSCC Dig. Tech. Papers*, 2014, pp. 346–347.
- [2] D.-Y. Yoon, *et al.*, "A new approach to low-power and low-latency wake-up receiver system for wireless sensor nodes," *IEEE J. Solid-State Circuits*, vol. 47, no. 10, pp. 2405–2419, Oct. 2012.
- [3] J. Choi, *et al.*, "An interference-aware 5.8 GHz wake-up radio for ETCS," in *IEEE ISSCC Dig. Tech. Papers*, 2012, pp. 446–447.
- [4] X. Huang, *et al.*, "A 2.4 GHz/915 MHz 51 μ W wake-up receiver with offset and noise suppression," in *IEEE ISSCC Dig. Tech. Papers*, 2010, pp. 222–223.
- [5] S. Oh, *et al.*, "A 116 nW multi-band wake-up receiver with 31-bit correlator and interference rejection," in *Proc. IEEE CICC*, 2013, pp. 1–4.
- [6] T. Wada, *et al.*, "60-GHz, 9- μ W wake-up receiver for short-range wireless communications," in *Proc. ESSCIRC*, 2013, pp. 383–386.
- [7] K. Okada, *et al.*, "A 60-GHz 16QAM/8PSK/QPSK/BPSK direct-conversion transceiver for IEEE802.15.3c," *IEEE J. Solid-State Circuits*, vol. 46, no. 12, pp. 2988–3004, Dec. 2011.